



Profit from the Eagle Advantage®

Foodservice Division: (800) 441-8440

MHC/Retail Display Divisions: (800) 637-5100

FAX: (302) 653-2065

Product Announcement

Short Form Specifications

Eagle Refrigerated Egg Station, model RES-1. All stainless steel construction. Features include lift-up door, removable egg basket, and food pan for scrambled eggs. Auto defrost system with electronic thermostatic control. Foam-in-place insulation. Heat shields on both ends, removable for use in a cook's line.

Item #:	_____
Model #:	_____
Project #:	_____
SIS #:	_____

EG8122 Rev. 01/15



Refrigerated Egg Station Self-Contained Unit

Design & Construction Features

- All stainless steel construction.
- Available as self-contained drop-in or freestanding unit.
- Automatic defrost system.
- Foamed-in-place insulation.
- Electronic thermostatic control.
- Removable egg basket can hold up to five egg flats (30 eggs per flat, 150 eggs total).
- Includes 1/3-size pan for scrambled eggs.
- Lift-up door conveniently stays open.
- Heat shields for use in a cook's line come installed on both ends, easily removable without tools for ease of cleaning.
- 120V 11.0A with NEMA 5-15P cord & plug included.
- Constructed of NSF-7 standards, R404A refrigerant.
- Removable filter on condenser for easy cleaning.



egg station / drop-in unit shown built into griddle stand (not included)

With Eagle's new Refrigerated Egg Station, you will no longer have to scramble around the kitchen. The all-stainless steel construction houses an egg compartment with removable egg basket which holds up to five egg flats—30 eggs per flat, 150 eggs total—and a lift-up door that conveniently stays open. Heat shields on each side allow for use in a cook's line, and are easily removable for cleaning. With features including automatic defrost system, electronic thermostatic control, and foamed-in-place insulation, this unit is exactly what your kitchen needs.

For custom configuration or fabrication needs, contact our **SpecFAB® Division**.
Phone: (302) 653-3000. FAX: (302) 653-2065.
E-mail: quotes@eaglegrp.com





Profit from the Eagle Advantage®

Refrigerated Egg Station / Drop-In Unit

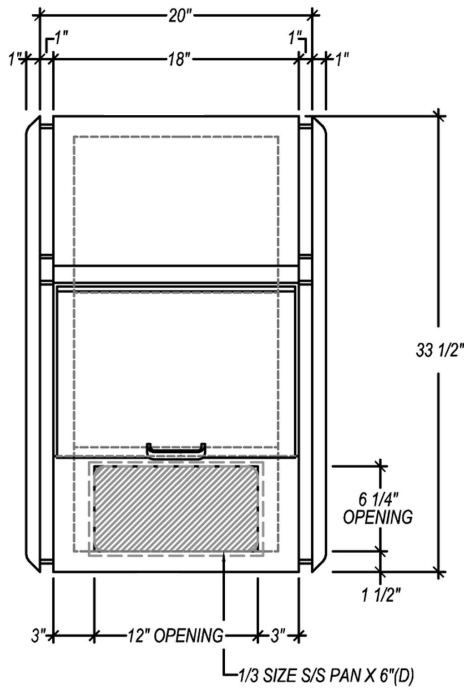

TOP VIEW

type of unit	overall side-to-side		overall front-to-back		overall height		weight		model #
	in.	mm	in.	mm	in.	mm	lbs.	kg	
drop-in unit	22"	559	33 1/2"	851	32"	813	189	85.7	RES-1

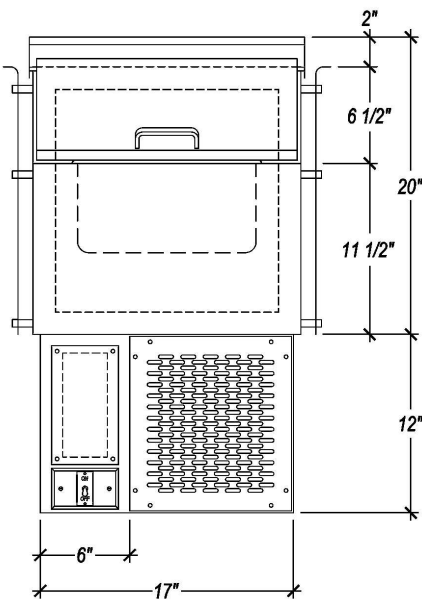

FRONT VIEW

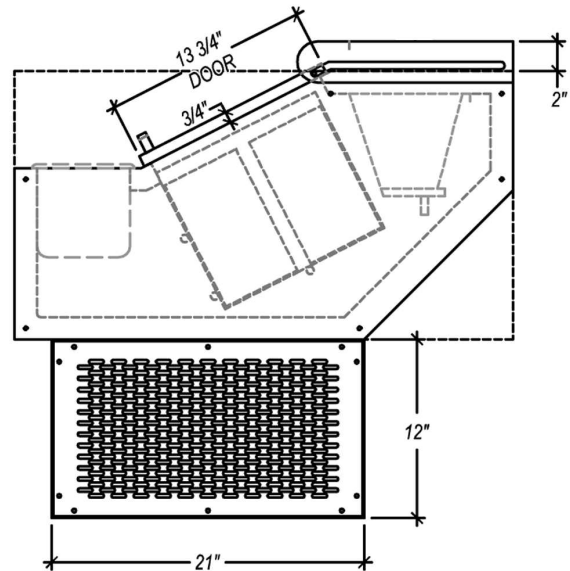

SIDE VIEW