



Profit from the Eagle Advantage®

Specification Sheet

Short Form Specifications

Eagle Wire Can Rack, model CRC. Chrome plated mild steel and heavy gauge wire construction. Front loading and dispensing, gravity fed. Capacity: eight #10 cans or twelve #5 cans.

Eagle Wire Can Rack System, model CRC2. Two-tier system with chrome plated bottom dunnage shelf, two 24" x 36" chrome plated wire shelves with patented QuadTruss® design, four 63" chrome plated posts, and standard can racks. Capacity: 124 #10 cans.

Eagle Wire Can Rack System, model _____. (Three-tier / Four-tier) system with 24" x 36" chrome plated wire shelves with patented QuadTruss® design, four chrome plated posts, and standard can racks.



#CRC wire can rack

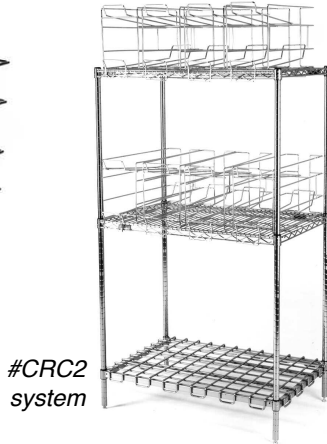

#CRC2 system

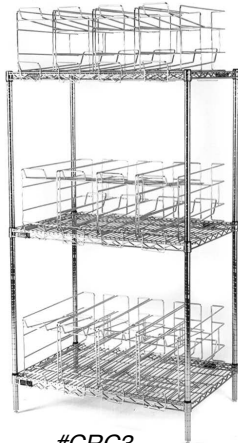

#CRC3

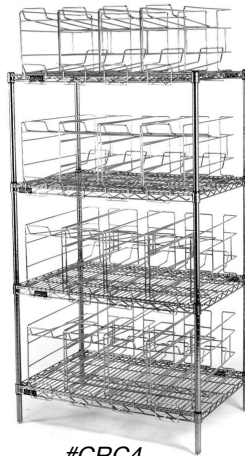

#CRC4

Item No.:	_____
Project No.:	_____
S.I.S. No.:	_____

Wire Can Racks and Wire Can Rack Systems

MODELS:

- CRC
- CRC2
- CRC3
- CRC4

Wire Can Rack

- 7¼"W x 27"D x 11½"H (197 x 686 x 292mm) can rack mounts onto 24" (610mm) wide shelves.
- Rack is front loading, front dispensing, gravity fed.
- Made of chrome-plated mild steel and heavy gauge wire.
- Each rack holds eight #10 cans or twelve #5 cans.

Wire Can Rack Systems

- Available in 2-tier plus bottom dunnage shelf, 3-tier with all wire shelves, or 4-tier with all wire shelves.
- Wire shelves feature patented QuadTruss® design (patent #5,390,803) for increased strength and durability.
- Consists of 24" x 36" (610 x 914mm) wire shelves, four 1" (25mm)-diameter posts, and standard can racks.
- Model #CRC2 features chrome-plated heavy duty dunnage shelf on the bottom.
- All components feature mirror chrome finish.

EAGLE GROUP
 100 Industrial Boulevard, Clayton, DE 19938-8903 USA
 Phone: 302-653-3000 • Fax: 302-653-2065
 www.eaglegrp.com

Foodservice Division: Phone 800-441-8440
MHC/Retail Display Divisions: Phone 800-637-5100

For custom configuration or fabrication needs, contact our **SpecFAB® Division**.
 Phone: 302-653-3000 • Fax: 302-653-2065 • e-mail: quotes@eaglegrp.com



EG01.15 Rev. 05/19

Spec sheets available for viewing, printing or downloading from our online literature library at www.eaglegrp.com

Eagle Foodservice Equipment, Eagle MHC, SpecFAB®, and Retail Display are divisions of Eagle Group. ©2019 by the Eagle Group



Item No.: _____
 Project No.: _____
 S.I.S. No.: _____

Wire Can Racks and Wire Can Rack Systems

Wire Can Rack

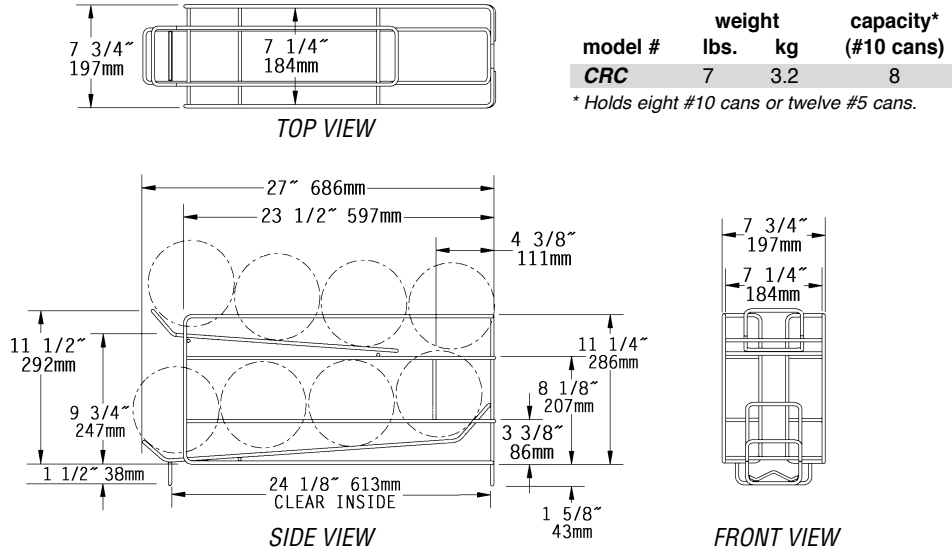

model #	weight		capacity* (#10 cans)
	lbs.	kg	
CRC	7	3.2	8

* Holds eight #10 cans or twelve #5 cans.

Wire Can Rack Systems

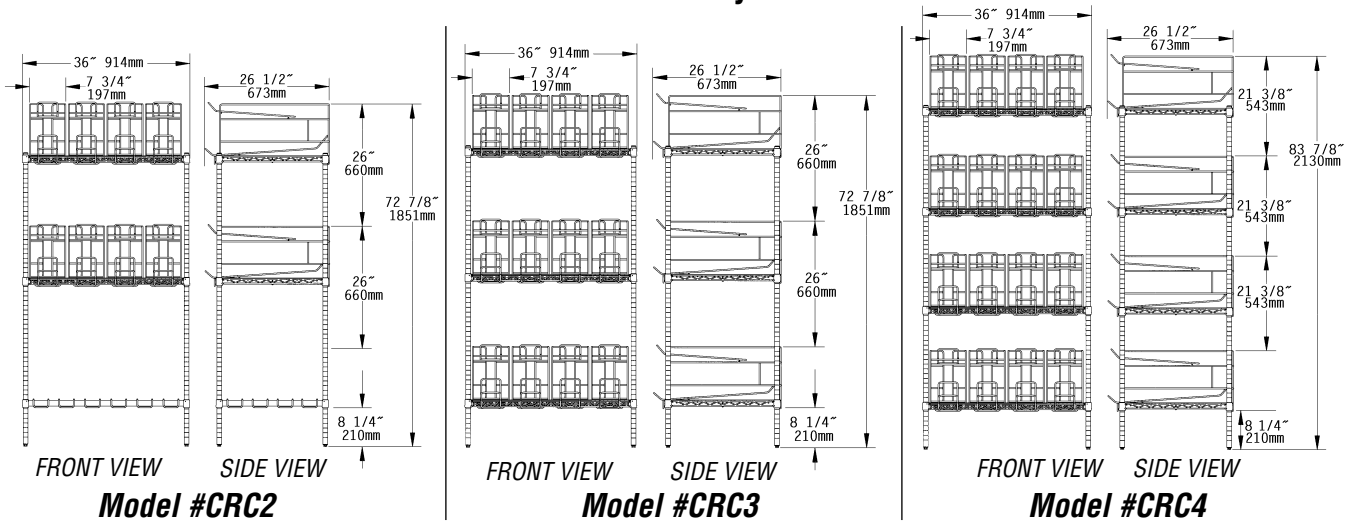

model #	description	weight		capacity (#10 cans)
		lbs.	kg	
CRC2*	wire can rack system with bottom dunnage and 63" (1600mm) posts	120	54.4	124
CRC3	3-tier with 24" x 36" (610 x 914mm) shelves and 63" (1600mm) posts	137	62.1	96
CRC4	4-tier with 24" x 36" (610 x 914mm) shelves and 74" (1880mm) posts	178	80.7	128

* #CRC2 system holds 64 racked cans plus 10 boxes of 6 cans each on the dunnage shelf.

EAGLE GROUP
 100 Industrial Boulevard, Clayton, DE 19938-8903 USA
 Phone: 302-653-3000 • Fax: 302-653-2065
 www.eaglegrp.com

Foodservice Division: Phone 800-441-8440
 MHC/Retail Display Divisions: Phone 800-637-5100

Printed in U.S.A.
 ©2019 by Eagle Group
 Rev. 05/19

Spec sheets available for viewing, printing or downloading from our online literature library at www.eaglegrp.com

Although every attempt has been made to ensure the accuracy of the information provided, we cannot be held responsible for typographical or printing errors. Information and specifications are subject to change without notice. Please confirm at time of order.